

Oval Head

METRIC

Machine Screws

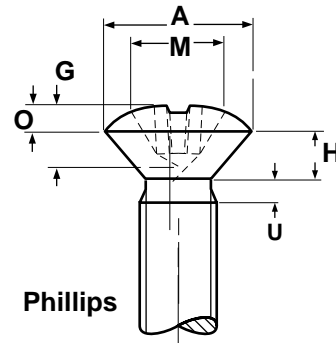
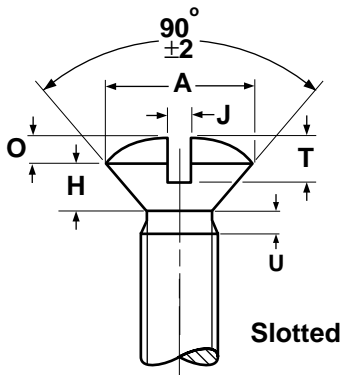

METRIC - PHILLIPS OVAL HEADS FOR MACHINE SCREWS										ISO 7047
Nominal Size	Thread Pitch	A		H	O	M	G		U	Phillips Driver Size
		Head Diameter		Head Side Height	Height of Oval	Recess Width	Recess Penetration		Thread Runout	
		Max	Min	Max	Ref	Ref	Max	Min	Max	
M1.6	0.35	3.0	2.7	1	0.4	1.9	1.2	0.9	0.7	0
M2	0.4	3.8	3.5	1.2	0.5	2	1.5	1.2	0.8	0
M2.5	0.45	4.7	4.4	1.5	0.6	3	1.85	1.50	0.9	1
M3	0.5	5.5	5.2	1.65	0.7	3.4	2.2	1.8	1	1
M4	0.7	8.40	8.04	2.7	1	5.2	3.2	2.7	1.4	2
M5	0.8	9.30	8.94	2.7	1.2	5.4	3.4	2.9	1.6	2
M6	1	11.30	10.87	3.3	1.4	7.3	4.0	3.5	2	3
M8	1.25	15.80	15.37	4.65	2	9.6	5.25	4.75	2.5	4
M10	1.5	18.30	17.78	5	2.3	10.4	6.0	5.5	3	4

METRIC - SLOTTED OVAL HEADS FOR MACHINE SCREWS										ISO 2010
Nominal Size	Thread Pitch	A		H	O	J		T		U
		Head Diameter		Head Side Height	Height of Oval	Width of Slot		Depth of Slot		Thread Runout
		Max	Min	Max	Ref	Max	Min	Max	Min	Max
M1.6	0.35	3.0	2.7	1	0.4	0.60	0.46	0.80	0.64	0.7
M2	0.4	3.8	3.5	1.2	0.5	0.70	0.56	1.0	0.8	0.8
M2.5	0.45	4.7	4.4	1.5	0.6	0.80	0.66	1.2	1.0	0.9
M3	0.5	5.5	5.2	1.65	0.7	1.00	0.86	1.45	1.20	1
M4	0.7	8.40	8.04	2.7	1	1.51	1.26	1.9	1.6	1.4
M5	0.8	9.30	8.94	2.7	1.2	1.51	1.26	2.4	2.0	1.6
M6	1	11.30	10.87	3.3	1.4	1.91	1.66	2.8	2.4	2
M8	1.25	15.80	15.37	4.65	2	2.31	2.06	3.7	3.2	2.5
M10	1.5	18.30	17.78	5	2.3	2.81	2.56	4.4	3.8	3