

# Rivets

**Aluminum Rivet/Steel Mandrel**  
**Steel Rivet/Steel Mandrel**  
**Stainless Rivet/Steel Mandrel**

**Countersunk Head**  
**Blind Rivet**

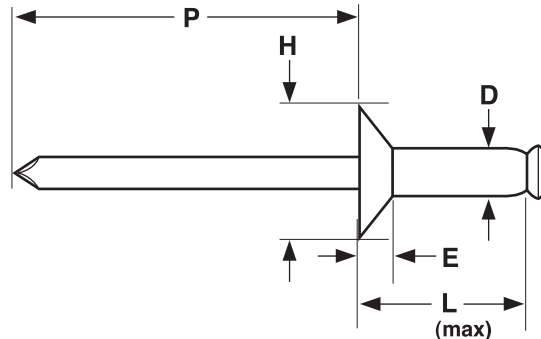

120° COUNTERSUNK HEAD BREAK-STEM BLIND RIVETS								SAE J-1200
Nominal Rivet Diameter	D		H		E	W	P	F
	Rivet Shank Diameter		Head Diameter		Head Height	Mandrel Diameter	Mandrel Protrusion	Blind Side Protrusion
	Max	Min	Max	Min	Max	Nom	Min	Max
1/8	.128	.122	.233	.207	.031	.076	1.00	L + 0.120
5/32	.159	.153	.294	.268	.040	.095	1.06	L + 0.140
3/16	.191	.183	.361	.335	.050	.114	1.06	L + 0.160

<b>Description</b>	A blind fastener with a self-contained carbon steel mandrel which permits the formation of an upset on the blind end of the rivet and expansion of the rivet shank during rivet setting. The steel mandrel is pulled into or against the rivet body, breaking at or near the junction of the mandrel shank and its upset end. The head of the rivet body is countersunk at an angle of 120°.
<b>Applications/ Advantages</b>	The countersunk head style provides a smooth offside surface and sufficient clearance for moving parts which pass over the rivet head. Aluminum rivets are the most lightweight of the three varieties profiled here, offer resistance to corrosion, but have the lowest tensile and shear values. Steel rivets have superior tensile and shear strength compared to aluminum, are less expensive than stainless rivets, but are less resistant to corrosion than either aluminum or stainless. Stainless rivets offer both corrosion resistance as well as the highest shear and tensile values.
<b>Material</b>	<b>Rivet Body:</b> <i>Aluminum</i> --Aluminum alloy 5052, 5056, 5154 or equivalent; <i>Steel</i> --Low carbon steel; <i>Stainless</i> --300-series stainless <b>Mandrel:</b> Carbon steel
<b>Shear Strength (Min.)</b>	<b>Aluminum Rivet/Steel Body--</b> 1/8: 170 lbs.; 5/32: 260 lbs.; 3/16: 380 lbs. <b>Steel Rivet/Steel Body--</b> 1/8: 260 lbs.; 5/32: 370 lbs.; 3/16: 540 lbs. <b>Stainless Rivet/Steel Body--</b> 1/8: 420 lbs.; 5/32: 650 lbs.; 3/16: 950 lbs.
<b>Tensile Strength (Min.)</b>	<b>Aluminum Rivet/Steel Body--</b> 1/8: 220 lbs.; 5/32: 350 lbs.; 3/16: 500 lbs. <b>Steel Rivet/Steel Body--</b> 1/8: 310 lbs.; 5/32: 470 lbs.; 3/16: 680 lbs. <b>Stainless Rivet/Steel Body--</b> 1/8: 530 lbs.; 5/32: 820 lbs.; 3/16: 1200 lbs.
<b>Mandrel Break Load</b>	<b>Aluminum Rivet/Steel Body--</b> 1/8: 400 - 600 lbs.; 5/32: 600 - 850 lbs.; 3/16: 750 - 1050 lbs. <b>Steel Rivet/Steel Body--</b> 1/8: 600 - 800 lbs.; 5/32: 750 - 1000 lbs.; 3/16: 1150 - 1450 lbs. <b>Stainless Rivet/Steel Body--</b> 1/8: 650 - 950 lbs.; 5/32: 1150 - 1450 lbs.; 3/16: 1400 - 1900 lbs.